

# FI-N



Rodete de álabes curvados hacia atrás  
 Backward curved impeller

Ventilador centrífugo de acoplamiento directo y simple aspiración. Fabricados en chapa de acero protegida contra la corrosión mediante tratamiento por cataforesis + pintura poliuretana. Temperaturas del aire a transportar -20°C/+100°C en continuo.

### Motores

De 2 polos, de alta eficiencia IE 3\*, tensión de alimentación trifásica 230/400V 50Hz hasta tamaño motor 112, y 400/690V 50Hz para motores de mayor dimensión. Protección IP55, Clase F.

\* A partir de 0,75 kW el motor puede ser de eficiencia IE 2 controlado por convertidor de frecuencia.

### Bajo pedido

- Fabricación en diferentes materiales constructivos.
- Motores de 2 velocidades.
- Versiones de 60 Hz.
- Pintura en diferentes RAL.
- Versión sin pie soporte (Motor-Brida, Sistema 5), hasta tamaño de motor 160.
- Versión para alta temperatura: hasta 220°C (versiones B: con rodete de refrigeración).
- SISTEMA 8: acoplamiento mediante junta elástica.

*Direct drive, single inlet centrifugal fan. Manufactured from steel sheet protected with cataforesis primer + polyurethane paint finish. Designed to continuously circulate air from -20°C up to 100°C.*

### Motors

2 pole, IE 3\* high efficiency, three-phase 230/400V 50Hz up to motor size 112 and 400/690V 50Hz for higher motors. IP55, Class F protection.

\* From 0,75kW, motor can be IE 2 and controlled by VSD.

### On request

- Manufactured from different materials.
- 2-speed motors.
- 60 Hz versions.
- Painted in different RAL colour.
- Fan with no supporting stand (Motor-Flange, Arrangement 5), up to motor size 160.
- High-temperature versions (up to 220°C) (B versions: with cooling impeller).
- ARRANGEMENT 8: with joint flexible coupling.

- Trampilla de inspección, purga de drenaje, distintos tipos de estanqueidad a nivel de voluta y de paso de eje.
- Ventiladores estancos.
- Calorifugado.

### Versiones ATEX

Bajo pedido, versiones antiexplosivas según la Directiva ATEX para modelos trifásicos:

Para trabajar a temperaturas de -20°C a +60°C, presión ambiente (absoluta) de 0,8 bar hasta 1,1 bar, según EN 14986.

#### • Gas:

- ⊗ 2G IIB T2-T3-T4\*
- ⊗ 2G IIB+H2 T2-T3-T4\*
- ⊗ 3G IIB T2-T3-T4\*
- ⊗ 3G IIB+H2 T2-T3-T4\*

#### • Polvo no conductivo:

- ⊗ 2D IIIB T125°C\*-T135°C\*-T195°C-T295°C
- ⊗ 3D IIIB T125°C\*-T135°C\*-T195°C-T295°C

#### • Polvo conductivo (con motor IP65 IIIC):

- ⊗ 2D IIIC T125°C\*-T135°C\*-T195°C-T295°C
- ⊗ 3D IIIC T125°C\*-T135°C\*-T195°C-T295°C

\* Viabilidad técnica solicitada.

- Inspection door, draining, different seals on scroll and shaft access.
- Welded casing.
- Thermal insulation lagging.

### ATEX versions

On request, explosion proof versions in accordance with ATEX directive for three phase models:

Ambient temperature -20°C to +60°C, ambient pressure (abs.) 0,8 bar to 1,1 bar according to EN 14986.

#### • Gas:

- ⊗ 2G IIB T2-T3-T4\*
- ⊗ 2G IIB+H2 T2-T3-T4\*
- ⊗ 3G IIB T2-T3-T4\*
- ⊗ 3G IIB+H2 T2-T3-T4\*

#### • Non-conductive dust:

- ⊗ 2D IIIB T125°C\*-T135°C\*-T195°C-T295°C
- ⊗ 3D IIIB T125°C\*-T135°C\*-T195°C-T295°C

#### • Conductive dust (compulsory IP65 IIIC motor):

- ⊗ 2D IIIC T125°C\*-T135°C\*-T195°C-T295°C
- ⊗ 3D IIIC T125°C\*-T135°C\*-T195°C-T295°C

\* Requested technical feasibility

CUADRO DE APLICACIONES TABLE OF APPLICATIONS	
Aire a transportar Air Type	Cantidad de polvo Dust quantity (mg/m <sup>3</sup> )
Aire limpio Clean air	<50

### CARACTERÍSTICAS TÉCNICAS / TECHNICAL FEATURES

Es imprescindible comprobar que las características eléctricas (voltaje, intensidad, frecuencia, etc.) del motor que aparecen en la placa del mismo son compatibles con las de la instalación.

Please, check that electrical features (voltage, current, frequency, etc.) are suitable with your installation.

Modelo Model	Tamaño motor Motor size	Velocidad Speed (r.p.m.)	Potencia motor Motor power (kW)	Intensidad motor 400V Maximum absorbed current 400V (A)	Caudal máximo Maximum airflow (m <sup>3</sup> /h)	Nivel presión sonora a 1 m Sound pressure level at 1 m (dB(A)) <sup>(1)</sup>	Peso Weight (kg) <sup>(2)</sup>	Momento de inercia Moment of inertia (kg·m <sup>2</sup> ) <sup>(3)</sup>
2 POLOS / 2 POLE								
FI 401/2 N4A	90L2	2850	2,2	4,43	3.000	78	56	0,15
FI 451/2 N4A	112M2	2910	4,0	7,50	4.320	81	83	0,28
FI 502/2 N4A	112M2	2910	4,0	7,50	3.400	83	98	0,35
FI 502/2 N4A	132SA2	2890	6,0	10,10	4.750	81	111	0,35
FI 501/2 N4A	132SA2	2890	5,5	10,10	5.860	87	112	0,40
FI 501/2 N4A	132SB2	2890	7,5	13,90	5.860	87	118	0,40
FI 562/2 N4A	132SB2	2890	7,5	13,90	6.840	88	138	0,58
FI 562/2 N4A	132MB2	2900	9,2	16,60	6.840	88	146	0,58
FI 561/2 N4A	132MB2	2900	9,2	16,60	8.360	88	148	0,70
FI 561/2 N4A	160MR2	2930	11,0	18,70	8.360	89	173	0,70
FI 632/2 N4A	160M2	2935	15,0	25,40	9.540	90	208	0,98
FI 631/2 N4A	160M2	2935	15,0	25,40	7.600	90	222	1,20
FI 631/2 N4A	160L2	2940	18,5	33,30	11.930	92	244	1,20
FI 712/2 N4A	180M2	2940	22,0	39,00	9.660	93	279	1,80
FI 712/2 N4A	200LR2	2960	30,0	53,50	13.500	93	395	1,80
FI 711/2 N4A	200LR2	2960	30,0	53,50	17.480	94	398	2,20
FI 711/2 N4A	200L2	2960	37,0	65,60	17.480	94	409	2,20
FI 802/2 N4A	225M2	2960	45,0	77,60	21.600	95	491	3,00
FI 802/2 N4A	250M2	2960	55,0	93,50	21.600	95	561	3,00
FI 801/2 N4A	250M2	2960	55,0	93,50	24.740	96	565	3,80
FI 801/2 N4A	280S2	2960	75,0	126,00	24.740	96	664	3,80
FI 902/2 N4A	280S2	2960	75,0	126,00	21.030	98	875	4,80
FI 902/2 N4A	280M2	2960	90,0	151,00	27.000	98	907	4,80
FI 901/2 N4A	280M2	2960	90,0	151,00	23.790	98	912	5,30
FI 901/2 N4A	315S2	2970	110,0	186,00	35.320	98	1.071	5,30
FI 1002/2 N4A	315M2	2970	132,0	220,00	38.160	100	1.150	9,00
FI 1002/2 N4A	315MG2	2975	160,0	263,00	38.160	100	1.200	9,00
FI 1001/2 N4A	315MG2	2975	160,0	263,00	48.490	100	1.120	12,30
FI 1001/2 N4A	315MK2	2980	200,0	336,00	48.490	100	1.300	12,30

<sup>1</sup> Entubado en la descarga / Piping only on outlet side

<sup>2</sup> Tolerancia del nivel de ruido de +3dB(A, medido en el punto de máxima eficiencia / Noise level tolerance +3 dB(A, measured in the maximum efficiency point

<sup>3</sup> Con motor incluido y para orientación LG270 o RD270 / With motor included and for LG270 or RD270 position

<sup>3</sup> Momento de inercia del rodetes / Impeller's moment of inertia

**CURVAS CARACTERÍSTICAS (a la descarga/a la aspiración) / PERFORMANCE CURVES (at outlet/inlet)**

- Caudal en m<sup>3</sup>/h.
  - **Psf: Presión estática en Pa.**
  - Modelo - Potencia motor en kW.
  - Ejemplo: 451 - 11  
     Modelo - kW
- Air volume in m<sup>3</sup>/h.
  - **Psf: Static pressure in Pa.**
  - Model - Motor power in kW.
  - Example: 451 - 11  
     Model - kW

2 polos - Descarga - Modelos desde 401 hasta 1001  
 2 pole - Outlet - Models from 401 to 1001

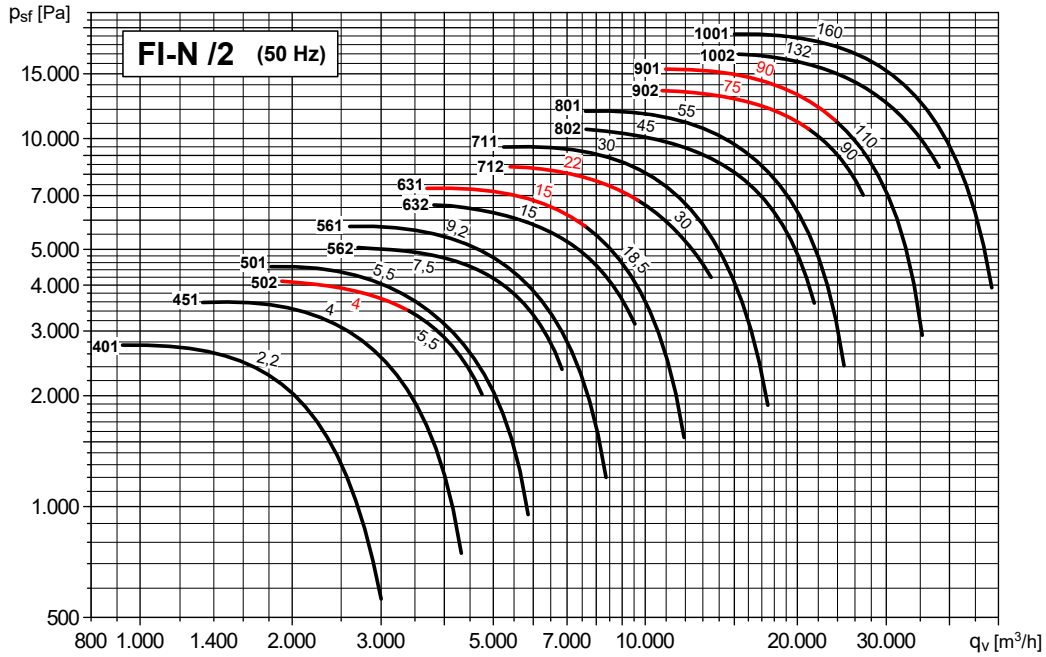

2 polos - Aspiración - Modelos desde 401 hasta 1001  
 2 pole - Inlet - Models from 401 to 1001

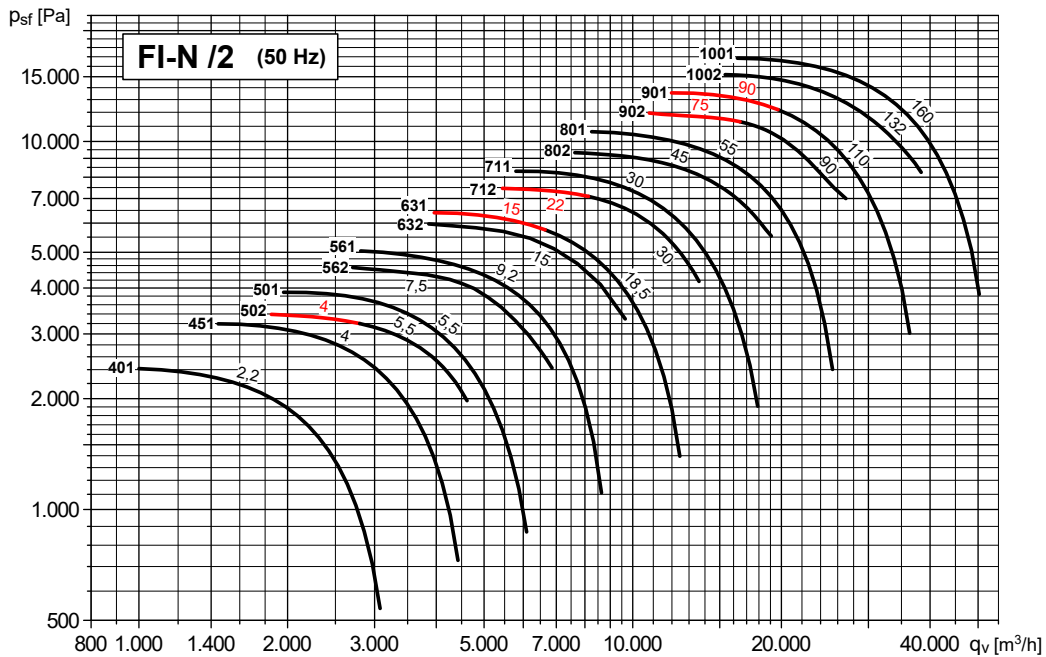

# RODETE ÁLABES CURVADOS HACIA ATRÁS - ACOPLAMIENTO DIRECTO BACKWARD CURVED IMPELLER - DIRECT DRIVE



## DIMENSIONES (mm) / DIMENSIONS (mm)

DESCARGA ORIENTABLE  
DISCHARGE ADJUSTABLE

**EJECUCIÓN B**  
Con rodete de refrigeración,  
contactar con oficina técnica.

**CONFIGURATION B**  
With cooling impeller, please  
contact our technical office.

**ORIENTACIONES / POSITIONS**

LG	0°	45°	90°	135°	180°	225°	270°	315°
RD	0°	45°	90°	135°	180°	225°	270°	315°
	H	H1			H2			H1

Para los ventiladores con orientaciones 180° y 225°, contactar con oficina técnica  
For fans with 180° and 225° positions, please contact our technical office

Tipo Type	Ventilador Fan	Motor GR Motor GR	Ventilador Fan											Base Base							
			A*	B	C	Ø D1	E	F	G	H		HT	mxl	Y	LT	L	P	M	Q	R	S
FI 401/2 N4A	90L2	475	310	280	265	217	280	83	375	280	655	M6X20	137	590	260	234	260	60	183	17	10
FI 451/2 N4A	112M2	570	345	315	292	242	300	92	400	300	715	M8X25	109	645	324	289	310	23	264	23	12
FI 501/2 N4A	132SA2	605	380	350	332	272	335	101	450	335	800	M8X25	120	715	372	337	360	23	314	23	12
FI 501/2 N4A	132SB2	605	380	350	332	272	335	101	450	335	800	M8X25	120	715	372	337	360	23	314	23	12
FI 502/2 N4A	132SA2	605	380	350	332	272	335	101	450	335	800	M8X25	120	715	372	337	360	23	314	23	12
FI 502/2 N4A	112M2	585	380	350	332	272	335	101	450	335	800	M8X25	120	715	324	289	310	23	264	23	12
FI 561/2 N4A	160MR2	775	430	390	366	308	375	115	500	375	890	M8X25	135	805	440	395	470	28	414	28	14
FI 561/2 N4A	132MB2	690	430	390	366	308	375	115	500	375	890	M8X25	130	805	372	337	360	23	314	23	12
FI 562/2 N4A	132MB2	690	430	390	366	308	375	115	500	375	890	M8X25	130	805	372	337	360	23	314	23	12
FI 562/2 N4A	132SB2	650	430	390	366	308	375	115	500	375	890	M8X25	130	805	372	337	360	23	314	23	12
FI 631/2 N4A	180M2	835	485	440	405	348	425	127	560	425	1000	M8X25	153	910	488	434	540	33	474	33	17
FI 631/2 N4A	160L2	795	485	440	405	348	425	127	560	425	1000	M8X25	148	910	440	395	470	28	414	28	14
FI 632/2 N4A	160M2	795	485	440	405	348	425	127	560	425	1000	M8X25	148	910	440	395	470	28	414	28	14
FI 711/2 N4A	200L2	985	540	490	448	389	475	140	630	475	1120	M8X25	213	1015	568	506	515	80	396	39	19
FI 711/2 N4A	200LR2	985	540	490	448	389	475	140	630	475	1120	M8X25	213	1015	568	506	515	80	396	39	19
FI 712/2 N4A	180M2	855	540	490	448	389	475	140	630	475	1120	M8X25	166	1015	488	434	540	33	474	33	17
FI 712/2 N4A	200LR2	985	540	490	448	389	475	140	630	475	1120	M8X25	213	1015	568	506	515	80	396	39	19
FI 801/2 N4A	280S2	1260	610	550	497	440	530	161	710	530	1260	M8X25	250	1140	770	690	714	100	564	50	21
FI 801/2 N4A	250M2	1110	610	550	497	440	530	161	710	530	1260	M8X25	240	1140	676	604	624	90	490	44	19
FI 802/2 N4A	225M2	1050	610	550	497	440	530	161	710	530	1260	M8X25	230	1140	616	556	564	80	445	39	19
FI 802/2 N4A	250M2	1110	610	550	497	440	530	161	710	530	1260	M8X25	240	1140	676	604	624	90	490	44	19
FI 901/2 N4A	280M2	1270	685	620	551	496	600	177	800	600	1420	M8X25	268	1285	770	690	690	100	540	50	21
FI 901/2 N4A	315S2	1370	685	620	551	496	600	177	800	600	1420	M8X25	278	1285	850	760	800	110	635	55	21
FI 902/2 N4A	280S2	1270	685	620	551	496	600	177	800	600	1420	M8X25	268	1285	770	690	690	100	540	50	21
FI 902/2 N4A	280M2	1270	685	620	551	496	600	177	800	600	1420	M8X25	268	1285	770	690	690	100	540	50	21
FI 1001/2 N4A	315MK2	1440	760	690	629	556	670	252	900	670	1590	M8X25	298	1430	850	760	800	110	635	55	21
FI 1001/2 N4A	315MG2	1440	760	690	629	556	670	252	900	670	1590	M8X25	298	1430	850	760	800	110	635	55	21
FI 1002/2 N4A	315M2	1440	760	690	629	556	670	252	900	670	1590	M8X25	298	1430	850	760	800	110	635	55	21
FI 1002/2 N4A	315MG2	1440	760	690	629	556	670	252	900	670	1590	M8X25	298	1430	850	760	800	110	635	55	21

\* Según tamaño motor / Depending on motor size

# RODETE ÁLABES CURVADOS HACIA ATRÁS - ACOPLAMIENTO DIRECTO

## BACKWARD CURVED IMPELLER - DIRECT DRIVE

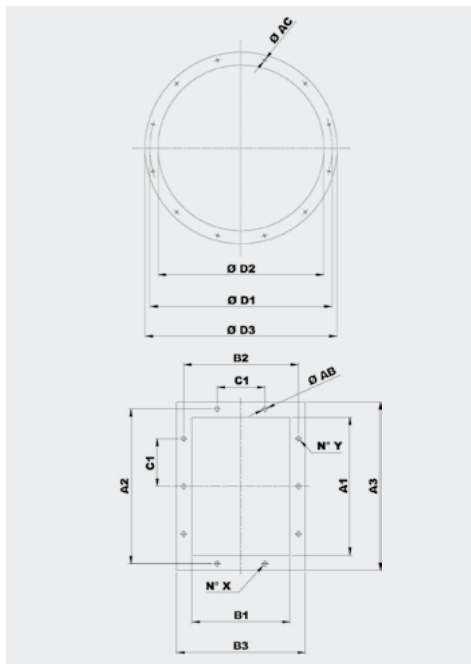

Modelo Model	Brida aspiración Inlet flange					
	Tipo brida Bride type	Ø D1	Ø D2	Ø D3	Ø AC	Agujeros Holes
401	224	265	228	298	8	8
451	250	292	254	324	10	8
501	280	332	285	365	10	8
561	315	366	320	400	10	8
631	355	405	360	440	10	8
711	400	448	405	485	10	12
801	450	497	455	535	10	12
901	500	551	505	585	10	12
1001	560	629	566	666	10	12

Modelo Model	Brida descarga Discharge flange										
	Tipo brida Bride type	A1	B1	A2	B2	A3	B3	C1	Ø AB	N°X	N°Y
401	200x140	205	146	241	182	275	216	112	12	2+2	2+2
451	224x160	229	164	265	200	299	234	112	12	2+2	2+2
501	250x180	256	183	292	219	326	253	112	12	2+2	3+3
561	280x200	288	205	332	249	368	285	125	12	2+2	3+3
631	315x224	322	229	366	273	402	309	125	12	2+2	3+3
711	355x250	361	256	405	300	441	336	125	12	2+2	3+3
801	400x280	404	288	448	332	484	368	125	12	3+3	4+4
901	450x315	453	322	497	366	533	402	125	12	3+3	4+4
1001	500x355	507	361	551	405	587	441	125	12	3+3	4+4

### AMORTIGUADORES / SILENT BLOCKS

Amortiguadores recomendados / Suggested silent blocks	
Ventilador / Fan	Ejecución 4 / Arrangement 4
401	4 x AM25 - 25 x 20
451	4 x AM25 - 25 x 20
501/2	4 x AM30 - 30 x 30
561/2	4 x AM40 - 40 x 30
631/2	4 x AM50 - 50 x 40
711/2	4 x AM75 - 75 x 50
801/2	4 x AM75 - 75 x 50
901/2	4 x AZ 39 - 140 x 39
1001/2	4 x AZ 39 - 140 x 39

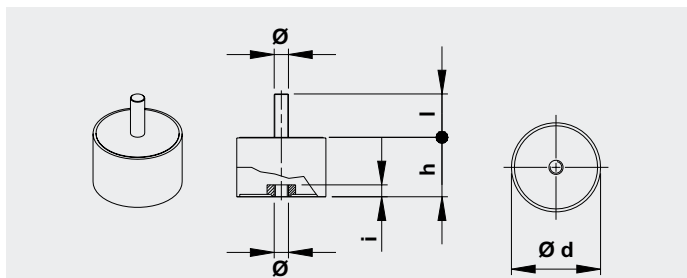

Tipo Type	Carga para 4 soportes Load for 4 supports (kg)	d	h	Ø	l	Peso Weight (kg)
AM25	41÷80	25	20	M6	18	0,03
AM30	81÷140	30	30	M8	20	0,05
AM40	141÷224	40	30	M8	23	0,10
AM50	225÷315	50	40	M10	28	0,20
AM75	316÷630	75	50	M12	37	0,50

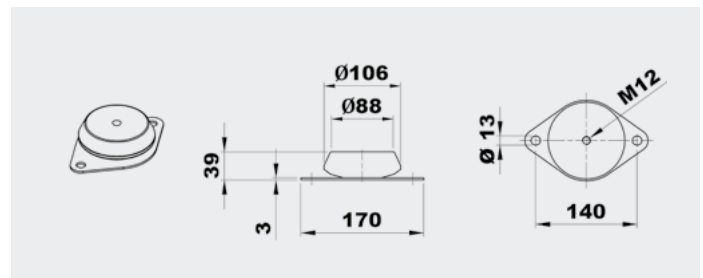

Tipo Type	Carga para 4 soportes Load for 4 supports (kg)	Peso Weight (kg)
AZ 39	631÷1250	0,7

ACCESORIOS / ACCESSORIES

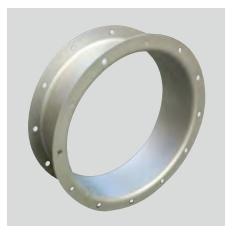

**CA (CFH1) - CFH2 - CFH3**  
 Contrabrida -  
 Brida plana circular.  
*Counter-flange -  
 Circular flange.*

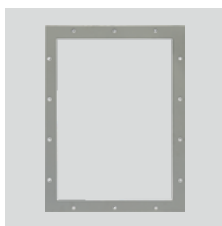

**CP**  
 Brida plana  
 rectangular.  
*Rectangular Flange.*

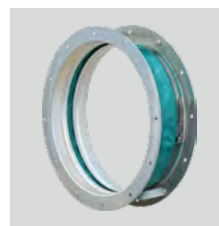

**GA**  
 Junta flexible  
 aspiración.  
*Inlet flexible  
 connector.*



**GP**  
 Junta flexible  
 descarga.  
*Outlet flexible  
 connector.*



**DP**  
 Regulador de caudal  
 de aspiración.  
*Inlet damper  
 governor.*



**SAD**  
 Compuerta de  
 regulación de caudal  
 de descarga.  
*Air reducing damper  
 at outlet.*



**SF**  
 Vávula mariposa.  
*Throttle valve.*



**DF**  
 Filtro en la  
 aspiración.  
*Air filter at inlet.*

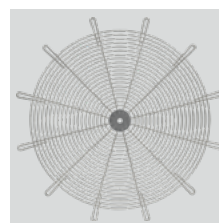

**RC**  
 Rejilla de protección  
 para la aspiración.  
*Protection net.*



**AM/AZ**  
 Soportes  
 antivibratorios.  
*Silent blocks.*



**SCSO**  
 Silenciador  
 cilíndrico.  
*Cylindrical sound  
 attenuator.*



**SCCO**  
 Silenciador cilíndrico  
 con bulbo.  
*Cylindrical sound  
 attenuator with  
 internal pot.*

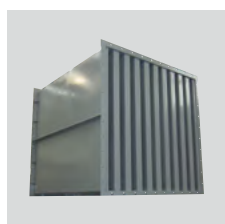

**SASS**  
 Silenciador  
 rectangular.  
*Baffle type sound  
 attenuator.*

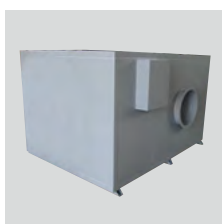

**CI**  
 Cabina de  
 insonorización.  
*Noise enclosure.*

Ver información completa en "Accesorios de montaje".  
 For more information see "Mounting accessories".

# FI-N

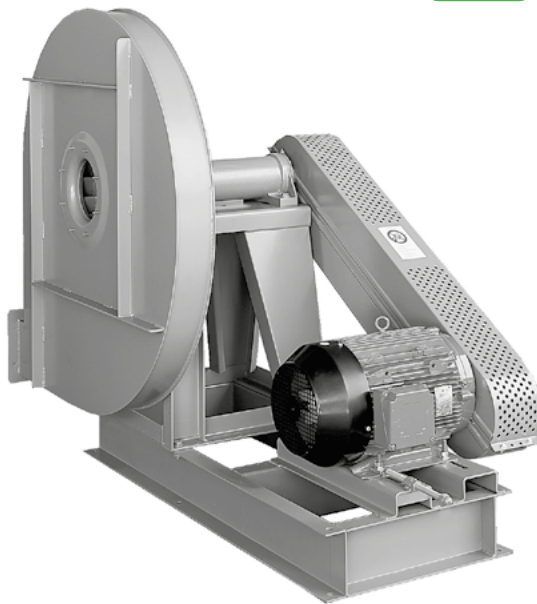

Rodete de álabes curvados hacia atrás  
 Backward curved impeller

Ventilador centrífugo con accionamiento por poleas y correas y simple aspiración. Fabricados en chapa de acero protegida contra la corrosión mediante tratamiento por cataforesis + pintura poliuretana. Temperaturas del aire a transportar -20°C/+100°C en continuo.

### Sistemas de montaje

- SISTEMA 1: eje libre, para acoplamiento mediante poleas y correas.
- SISTEMA 9: incluye motor, poleas, correas y protector de correas. Motor montado en el lateral del pie soporte rodamientos.
- SISTEMA 12: incluye motor, poleas, correas y protector de correas. Motor montado sobre la bancada general.

### Motores

De 2, 4 o 6 polos, de alta eficiencia IE 3\* (las r.p.m. de cada motor se adaptarán al cálculo de cada transmisión), tensión de alimentación trifásica 230/400V 50Hz hasta tamaño motor 112 y 400/690V 50Hz para motores de mayor dimensión. Protección IP55, Clase F.

\* A partir de 0,75 kW el motor puede ser de eficiencia IE 2 controlado por convertidor de frecuencia.

### Bajo pedido

- Fabricación en diferentes materiales constructivos.
- Motores de 2 velocidades.
- Versiones de 60 Hz.
- Pintura en diferentes RAL.
- Versión para alta temperatura: hasta 300°C (versiones B: con rodete de refrigeración).
- Trampilla de inspección, purga de drenaje, distintos tipos de estanqueidad a nivel de voluta y de paso de eje.
- Ventiladores estancos.
- Calorifugado.

### Versiones ATEX

Bajo pedido, versiones antiexplosivas según la Directiva ATEX para modelos trifásicos:

Para trabajar a temperaturas de -20°C a +60°C, presión ambiente (absoluta) de 0,8 bar hasta 1,1 bar, según EN 14986.

- Gas:
  - ⊗ 2G IIB T2-T3
  - ⊗ 2G IIB+H2 T2-T3
  - ⊗ 3G IIB T2-T3
  - ⊗ 3G IIB+H2 T2-T3
- Polvo no conductivo:
  - ⊗ 2D IIIB T195°C-T295°C
  - ⊗ 3D IIIB T195°C-T295°C
- Polvo conductivo (con motor IP65 IIIC):
  - ⊗ 2D IIIC T195°C-T295°C
  - ⊗ 3D IIIC T195°C-T295°C

CUADRO DE APLICACIONES TABLE OF APPLICATIONS	
Aire a transportar Air Type	Cantidad de polvo Dust quantity (mg/m <sup>3</sup> )
Aire limpio Clean air	<50

Single inlet centrifugal fans, for belt drive. Manufactured from steel sheet protected with cataforesis primer + polyurethane paint finish. Designed to continuously circulate air from -20°C up to 100°C.

### Assembly systems

- ARRANGEMENT 1: Free shaft, for pulley or belt-drive.
- ARRANGEMENT 9: Includes motor, pulleys, belts and belt guard. Motor fitted on the side of the bearing mounting bracket.
- ARRANGEMENT 12: Includes motor, pulleys, belts and belt guard. Motor fitted on the base frame.

### Motors

2, 4 or 6 pole, IE 3\* high efficiency (the rpm of each motor will be adapted according to the calculation for each drive), three-phase 230/400V 50Hz up to motor size 112 and 400/690V 50Hz for higher motors. IP55, Class F protection.

\* From 0,75kW, motor can be IE 2 and controlled by VSD.

### On request

- Manufactured from different materials.
- 2-speed motors.
- 60 Hz versions.
- Painted in different RAL colour.
- High-temperature versions (up to 300°C) (B versions: with cooling impeller).
- Inspection door, draining, different seals on scroll and shaft access.
- Welded casing.
- Thermal insulation lagging.

### ATEX versions

On request, explosion proof versions in accordance with ATEX directive for three phase models:

Ambient temperature -20°C to +60°C, ambient pressure (abs.) 0,8 bar to 1,1 bar according to EN 14986.

- Gas:
  - ⊗ 2G IIB T2-T3
  - ⊗ 2G IIB+H2 T2-T3,
  - ⊗ 3G IIB T2-T3
  - ⊗ 3G IIB+H2 T2-T3
- Non-conductive dust:
  - ⊗ 2D IIIB T195°C-T295°C
  - ⊗ 3D IIIB T195°C-T295°C
- Conductive dust (compulsory IP65 IIIC motor):
  - ⊗ 2D IIIC T195°C-T295°C
  - ⊗ 3D IIIC T195°C-T295°C

# RODETE ÁLABES CURVADOS HACIA ATRÁS - ACOPLAMIENTO A TRANSMISIÓN BACKWARD CURVED IMPELLER - BELT DRIVE



## CARACTERÍSTICAS TÉCNICAS / TECHNICAL FEATURES

Es imprescindible comprobar que las características eléctricas (voltaje, intensidad, frecuencia, etc.) del motor que aparecen en la placa del mismo son compatibles con las de la instalación.

Please, check that electrical features (voltage, current, frequency, etc.) are suitable with your installation.

Modelo Model	Caudal máximo Maximum airflow (m <sup>3</sup> /h)	Potencia motor máxima Maximum motor power (kW)	Peso Weight (kg) <sup>(1)</sup>	Momento de inercia Moment of inertia (kg·m <sup>2</sup> ) <sup>(2)</sup>
FI 501 N1A	9.130	18,5	90	0,4
FI 561 N1A	11.420	22,0	130	0,7
FI 631 N1A	16.230	45,0	180	1,2
FI 711 N1A	20.960	55,0	230	2,2
FI 801 N1A	29.670	90,0	320	3,8
FI 901 N1A	37.460	110,0	480	5,3
FI 1001 N1A	51.260	160,0	770	12,0
FI 1121 N1A	64.510	200,0	830	20,0
FI 1251 N1A	80.360	250,0	1.140	32,0
FI 1401 N1A	100.400	315,0	1.247	61,0
FI 1601 N1A	135.000	400,0	1.660	80,0
FI 1801 N1A	170.100	630,0	2.220	140,0
FI 2001 N1A	211.970	710,0	2.915	269,0

<sup>1</sup> Para ejecución 1 y orientación LG270 o RD270 / For arrangement 1 and LG270 or RD270 position

<sup>2</sup> Momento de inercia del rodetete / Impeller's moment of inertia

## SOPORTES SISTEMA 1 / SUPPORTS FOR ARRANGEMENT 1

Modelo Model	401	451-501	561	631	711	801	901	1001
Soporte tipo Support type	ST 80 A28	ST 90 A38	ST 100 A42	ST 110 B48	ST 120 B48	ST 130 B55	ST 150 B65	ST 180 B80

Ver información adicional / See additional information

## MOTORES SISTEMA 9 / MOTOR SIZE FOR ARRANGEMENT 9

Modelo Model	401-501	561-631	711-801	901-1001
Tamaño motor Motor size	≤ 132 M2	≤ 160 L2	≤ 180 L2-4	≤ 200 L2-4



**CURVAS CARACTERÍSTICAS (a la descarga) / PERFORMANCE CURVES (at outlet)**

- Ptot: Presión total en Pa.  
 - Ptot: Total pressure in Pa.

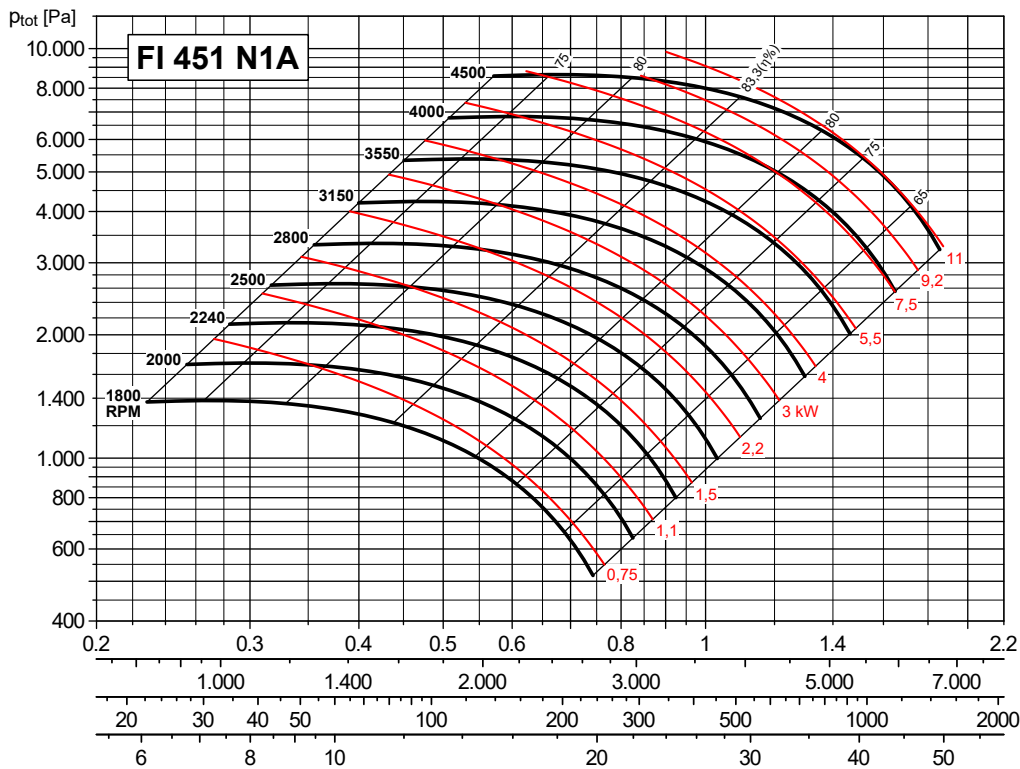
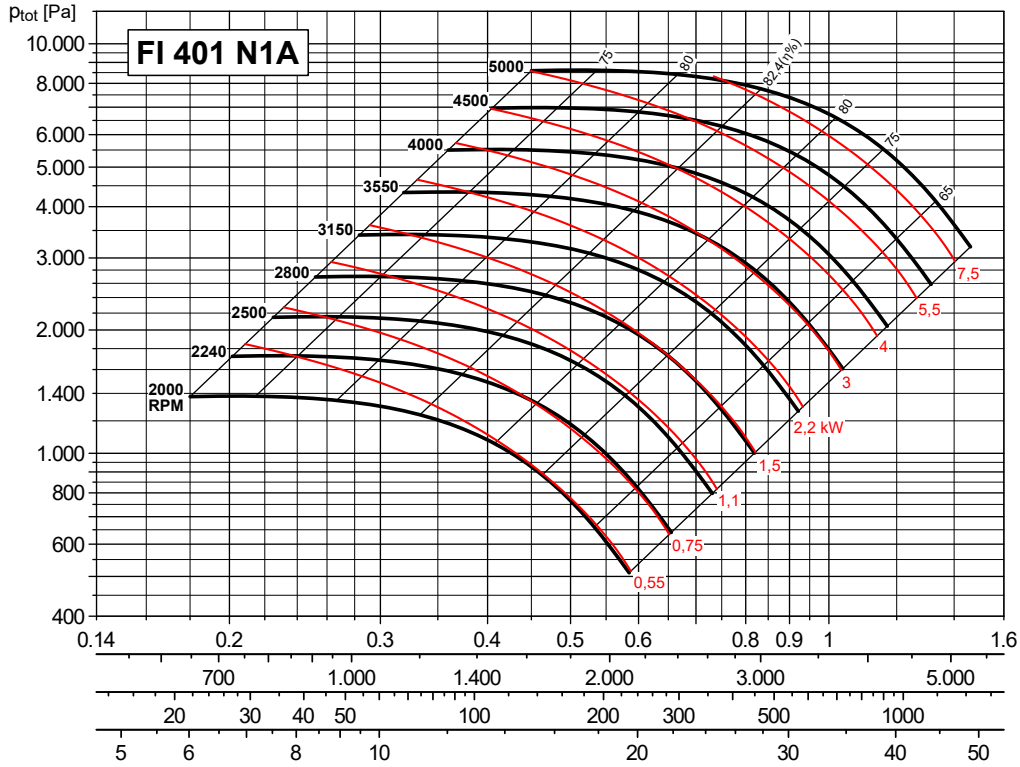

**CURVAS CARACTERÍSTICAS (a la descarga) / PERFORMANCE CURVES (at outlet)**

- Ptot: Presión total en Pa.  
 - Ptot: Total pressure in Pa.

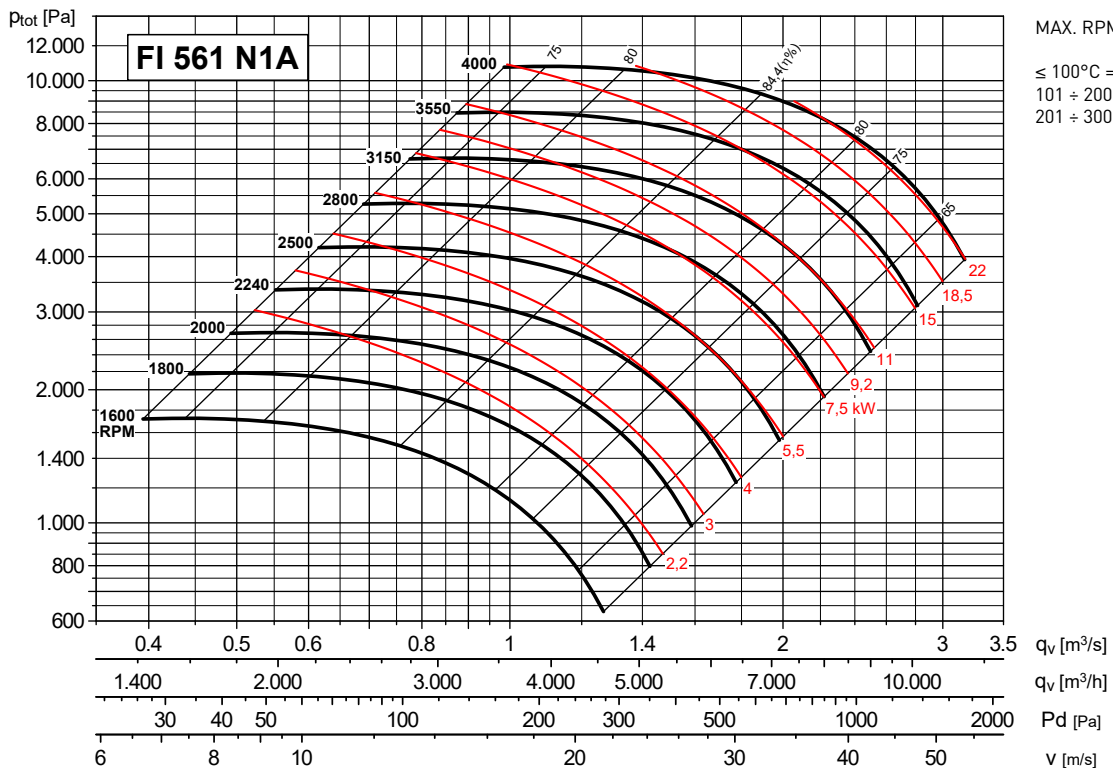
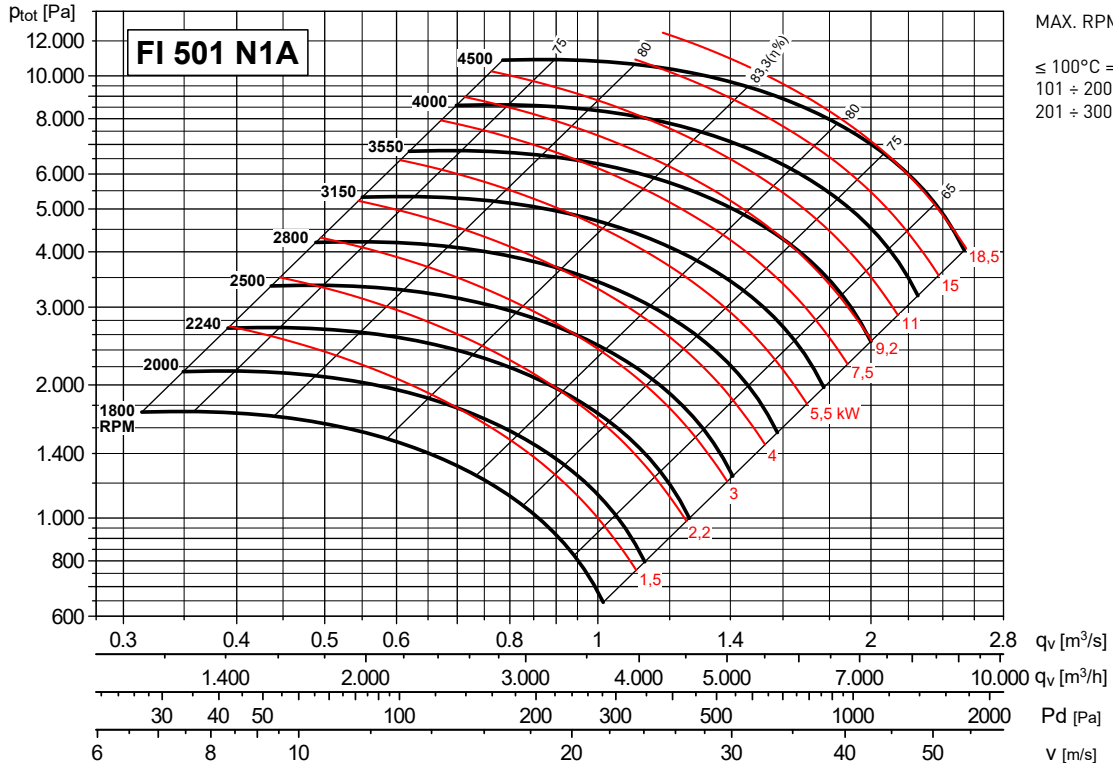

**CURVAS CARACTERÍSTICAS (a la descarga) / PERFORMANCE CURVES (at outlet)**

- Ptot: Presión total en Pa.  
 - Ptot: Total pressure in Pa.

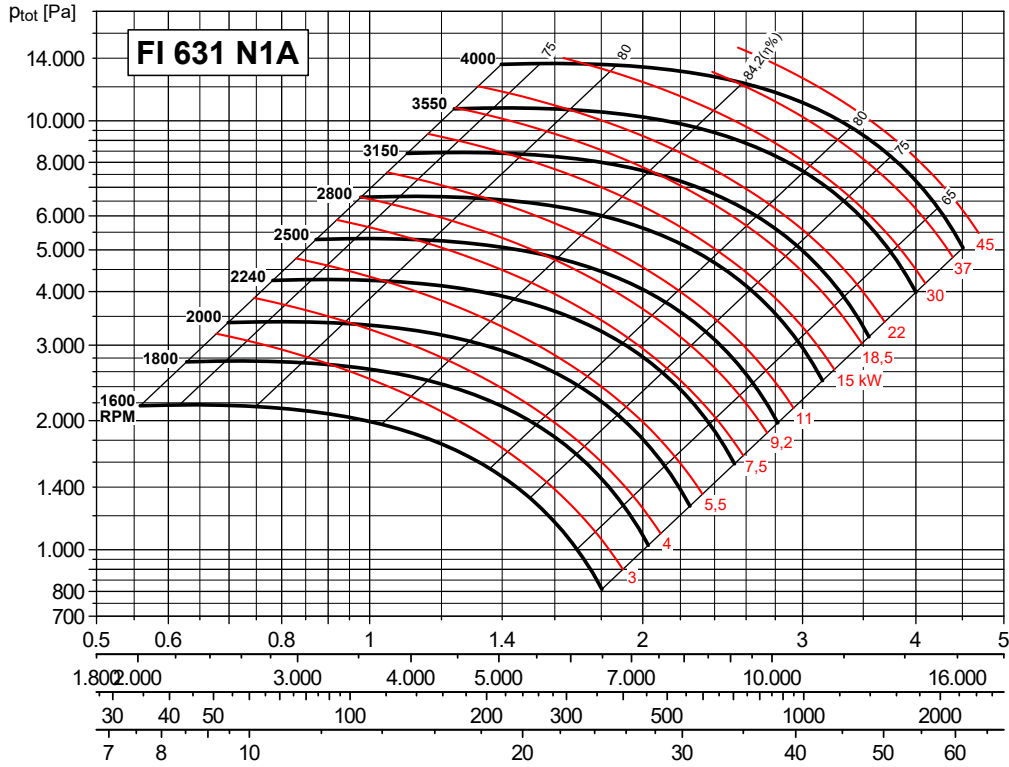

MAX. RPM

≤ 100°C = 3550 rpm  
 101 ÷ 200°C = 3150 rpm  
 201 ÷ 300°C = 2800 rpm

qv [m³/s]

qv [m³/h]

Pd [Pa]

v [m/s]

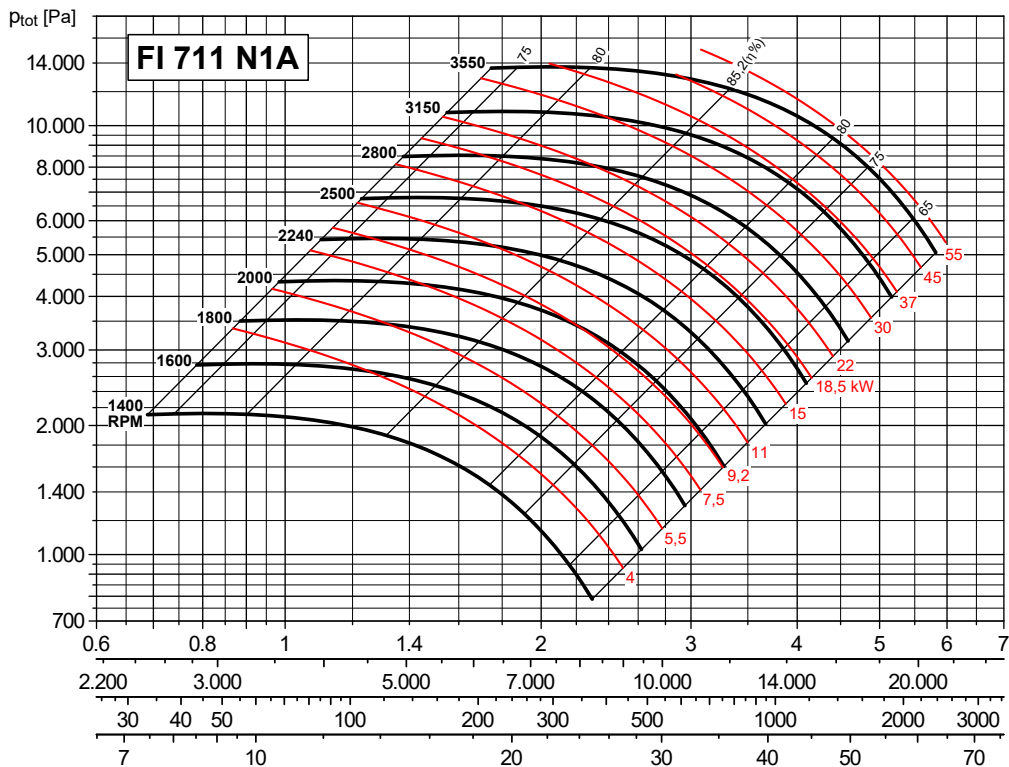

MAX. RPM

≤ 100°C = 3350 rpm  
 101 ÷ 200°C = 3000 rpm  
 201 ÷ 300°C = 2650 rpm

qv [m³/s]

qv [m³/h]

Pd [Pa]

v [m/s]

**CURVAS CARACTERÍSTICAS (a la descarga) / PERFORMANCE CURVES (at outlet)**

- Ptot: Presión total en Pa.
- Ptot: Total pressure in Pa.

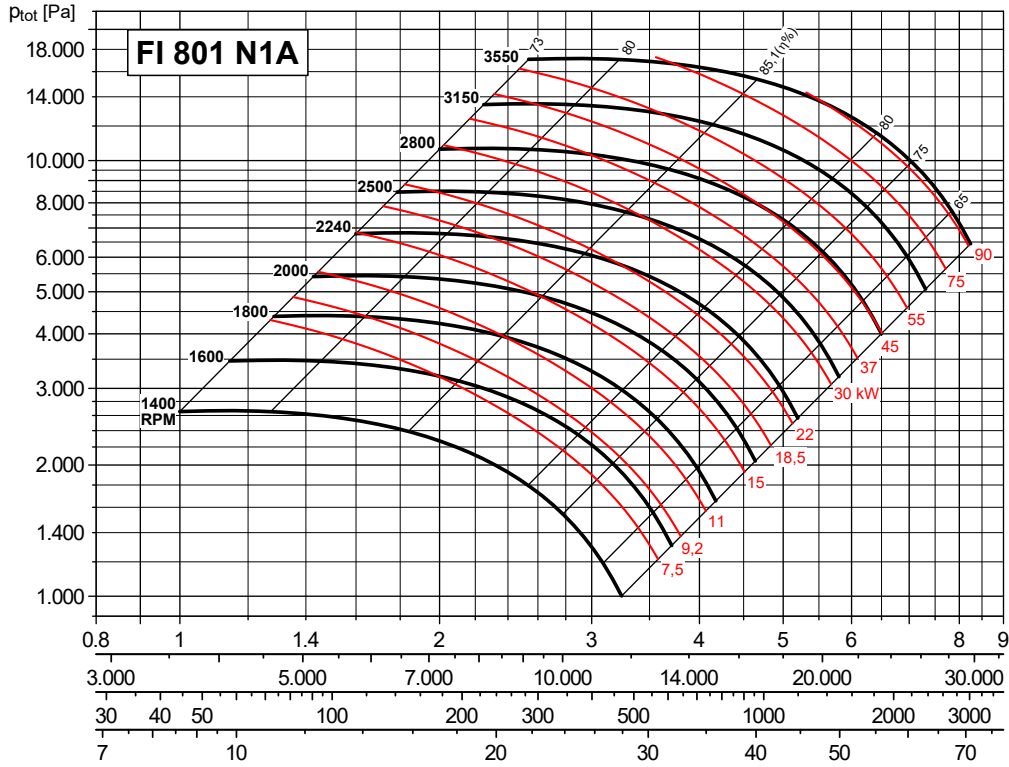

MAX. RPM  
 ≤ 100°C = 3150 rpm  
 101 ÷ 200°C = 2800 rpm  
 201 ÷ 300°C = 2500 rpm

q<sub>v</sub> [m<sup>3</sup>/s]  
 q<sub>v</sub> [m<sup>3</sup>/h]  
 Pd [Pa]  
 v [m/s]

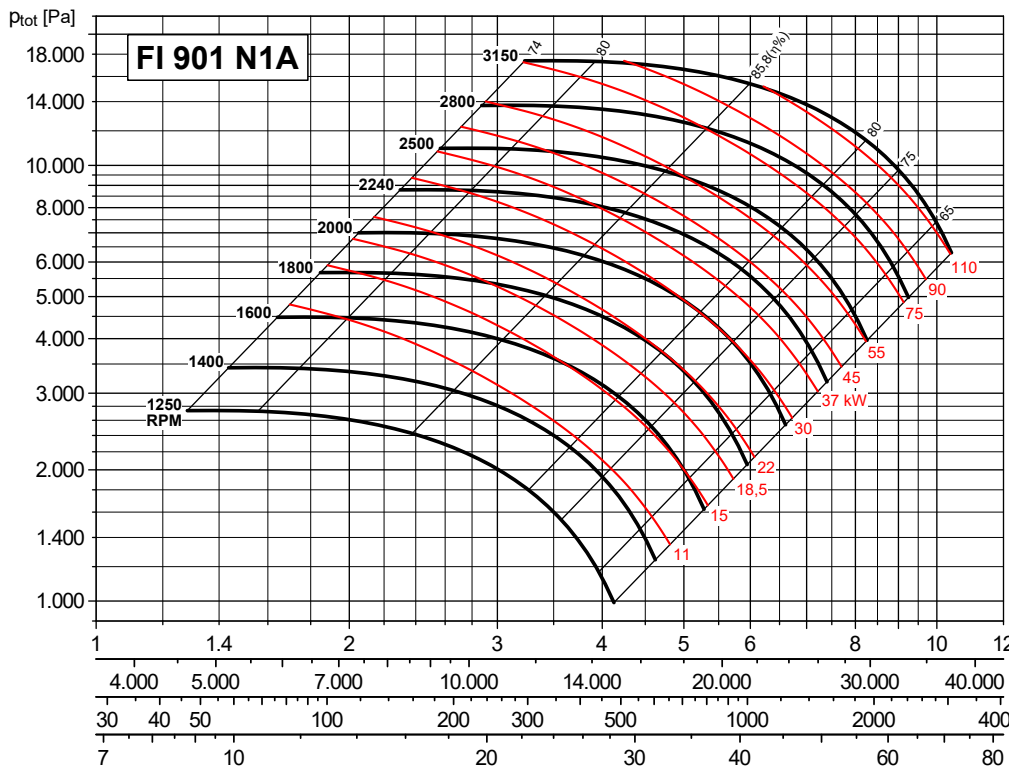

MAX. RPM  
 ≤ 100°C = 3000 rpm  
 101 ÷ 200°C = 2650 rpm  
 201 ÷ 300°C = 2360 rpm

q<sub>v</sub> [m<sup>3</sup>/s]  
 q<sub>v</sub> [m<sup>3</sup>/h]  
 Pd [Pa]  
 v [m/s]

**CURVAS CARACTERÍSTICAS (a la descarga) / PERFORMANCE CURVES (at outlet)**

- Ptot: Presión total en Pa.  
 - Ptot: Total pressure in Pa.

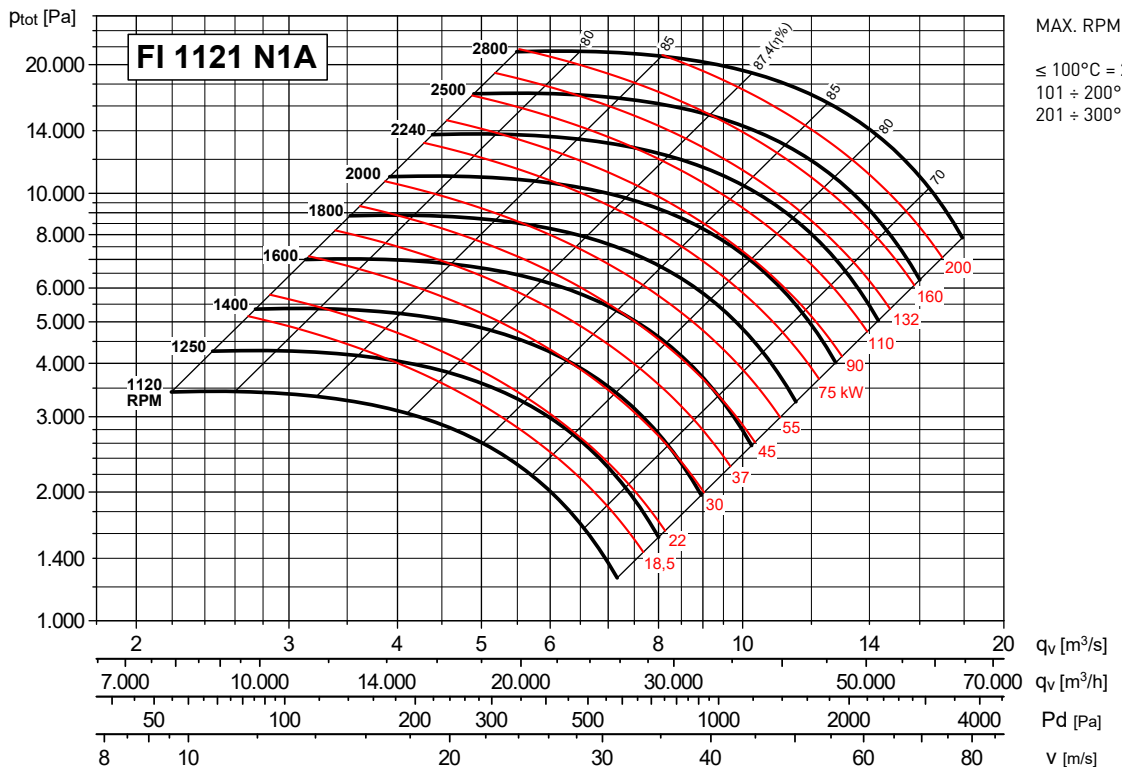
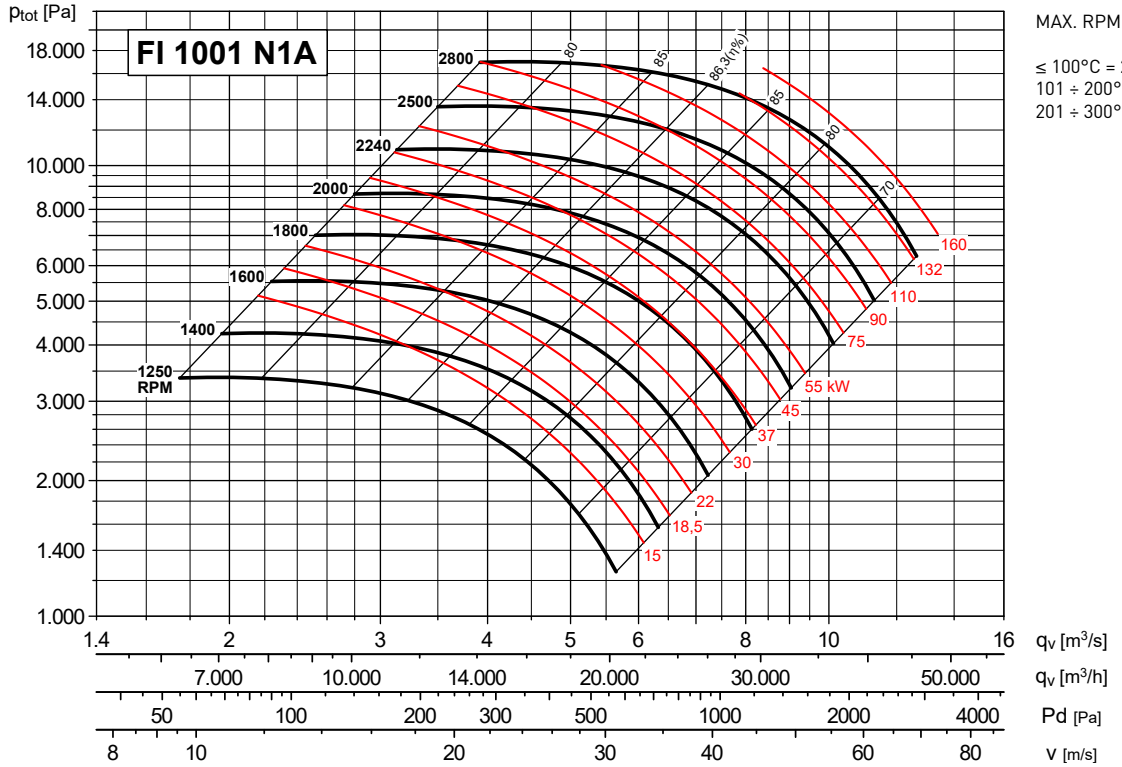

**CURVAS CARACTERÍSTICAS (a la descarga) / PERFORMANCE CURVES (at outlet)**

- Ptot: Presión total en Pa.  
 - Ptot: Total pressure in Pa.

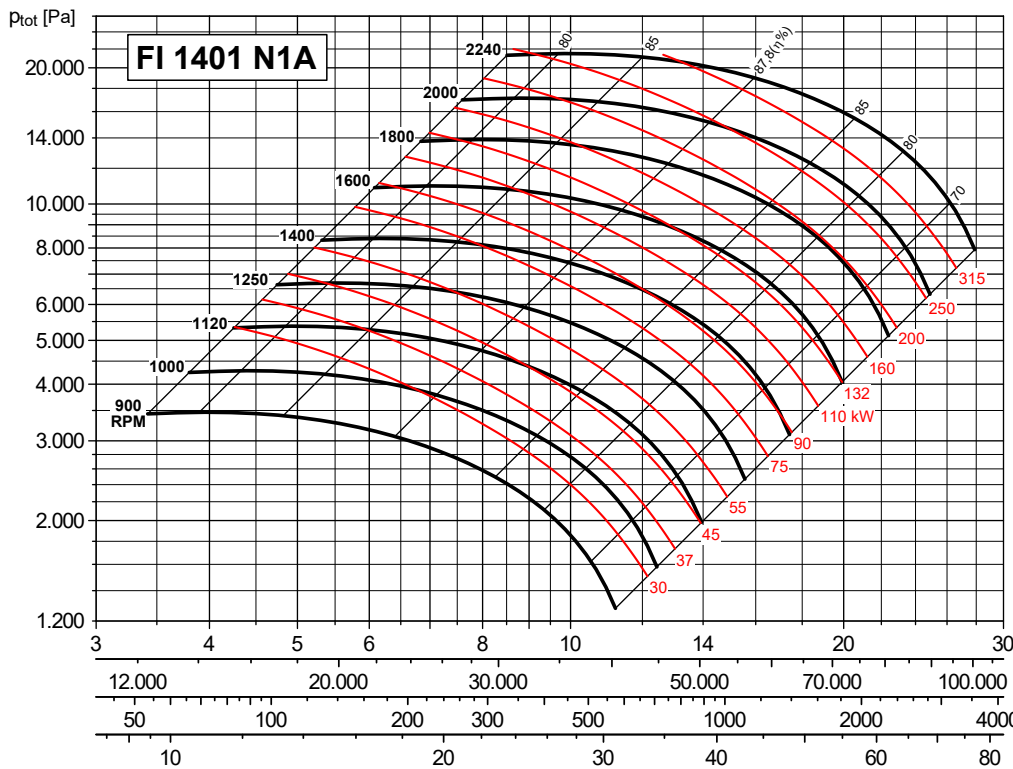
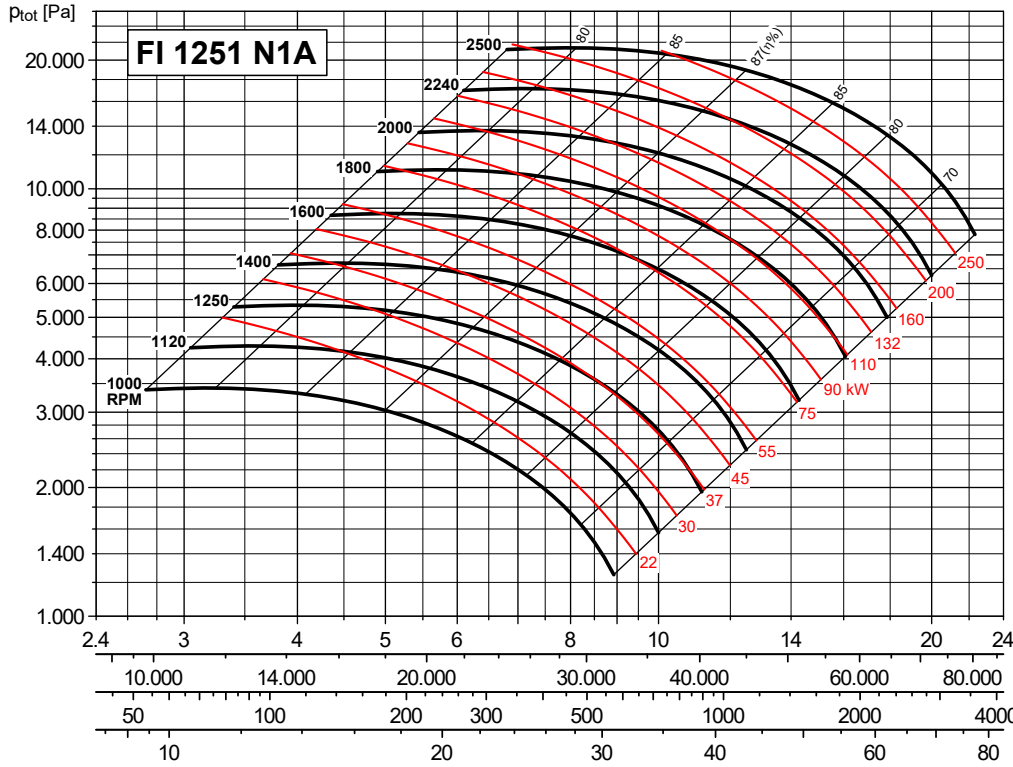

**CURVAS CARACTERÍSTICAS (a la descarga) / PERFORMANCE CURVES (at outlet)**

- Ptot: Presión total en Pa.  
 - Ptot: Total pressure in Pa.

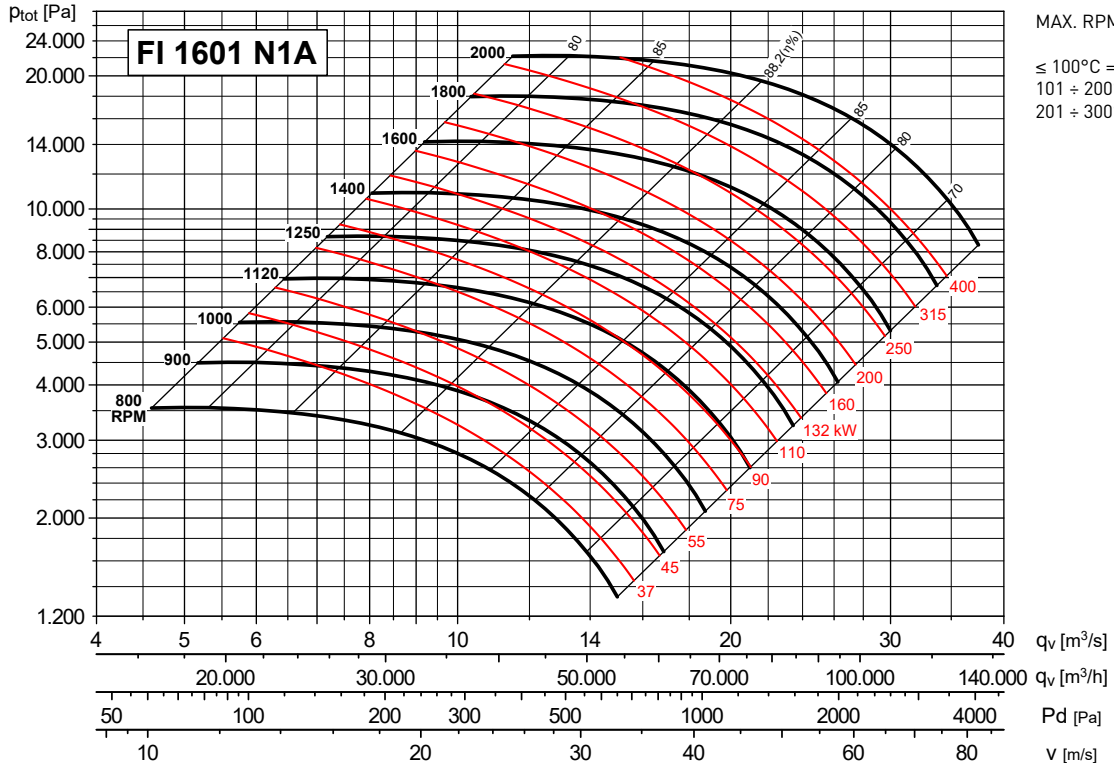

MAX. RPM  
 ≤ 100°C = 1800 rpm  
 101 ÷ 200°C = 1600 rpm  
 201 ÷ 300°C = 1400 rpm

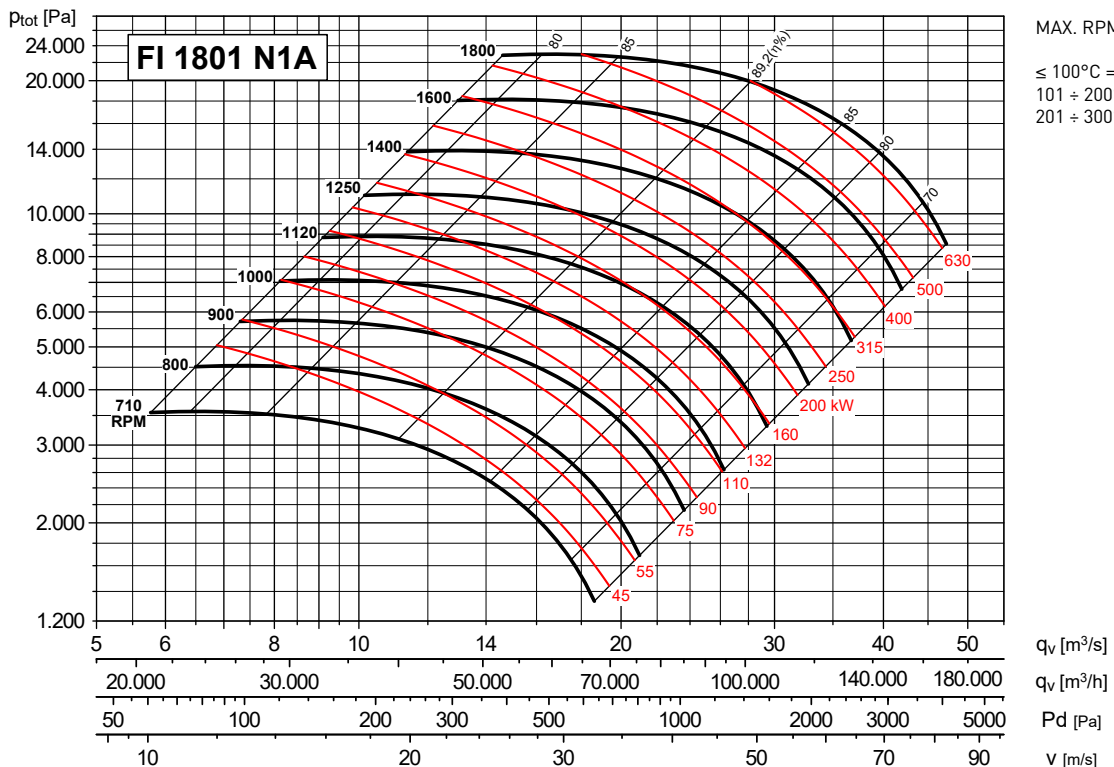

MAX. RPM  
 ≤ 100°C = 1600 rpm  
 101 ÷ 200°C = 1400 rpm  
 201 ÷ 300°C = 1250 rpm

**CURVAS CARACTERÍSTICAS (a la descarga) / PERFORMANCE CURVES (at outlet)**

- P<sub>tot</sub>: Presión total en Pa.
- P<sub>tot</sub>: Total pressure in Pa.

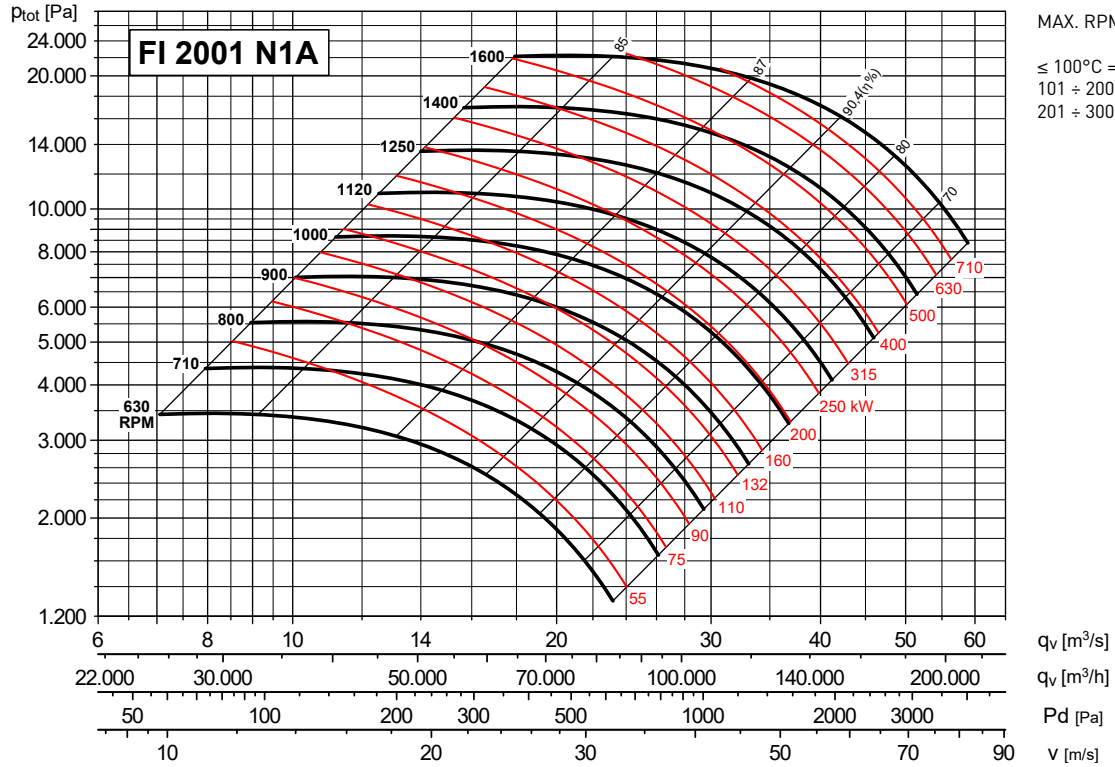



# RODETE ÁLABES CURVADOS HACIA ATRÁS - ACOPLAMIENTO A TRANSMISIÓN BACKWARD CURVED IMPELLER - BELT DRIVE



**DIMENSIONES (mm) (modelos desde 451 hasta 1001) / DIMENSIONS (mm) (models from 451 to 1001)**

DESCARGA ORIENTABLE  
DISCHARGE ADJUSTABLE

**EJECUCIÓN B**  
Con rodete de refrigeración,  
contactar con oficina técnica.

**CONFIGURATION B**  
With cooling impeller, please  
contact our technical office.

**ORIENTACIONES / POSITIONS**

	0°	45°	90°	135°	180°	225°	270°	315°
LG								
RD								
	H	H1	H2	H3	H4	H5		

Para estas orientaciones, contactar con oficina técnica  
For these positions, please contact our technical office

Tipo ventilador Fan type	Ventilador Fan											Eje Shaft		Base Base											
	A	B	C	ØD1	E	F	G	H					HT	mxl	Y	LT	L2	ØD	L	P	M	Q	R	S	ØAA
	H1	H2	H3	H4	H5																				
FI 401 N1A	720	310	280	265	217	280	83	375	375	280	375	375	655	M6X20	77	590	60	28	400	355	463	23	417	23	14
FI 451 N1A	765	345	315	292	242	300	92	400	400	300	400	400	715	M8X25	86	645	80	38	400	355	458	23	412	23	14
FI 501 N1A	780	380	350	332	272	335	101	450	450	335	450	450	800	M8X25	97	715	80	38	400	355	463	23	417	23	14
FI 561 N1A	930	430	390	366	308	375	115	500	500	375	500	500	890	M8X25	107	805	110	42	418	364	552	28	476	28	17
FI 631 N1A	945	485	440	405	348	425	127	560	560	425	560	560	1000	M8X25	120	910	110	48	418	364	535	28	479	28	17
FI 711 N1A	1035	540	490	448	389	475	140	530	530	475	630	630	1120	M8X25	133	1015	110	48	606	542	605	33	539	33	19
FI 801 N1A	1080	610	550	497	440	530	161	600	600	530	710	710	1260	M8X25	150	1140	110	55	646	582	614	33	548	33	19
FI 901 N1A	1220	685	620	551	496	600	177	670	670	600	800	800	1420	M8X25	168	1285	140	65	762	682	650	39	572	39	21
FI 1001 N1A	1365	760	690	629	556	670	252	750	750	670	900	900	1590	M8X25	188	1430	170	80	862	782	710	39	632	39	21

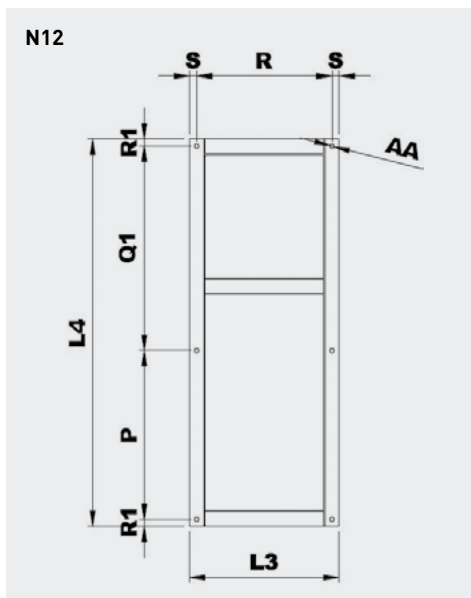

Modelo Model	Bancada ejecución 12 Base frame arrangement 12								Peso Weight (kg)
	P	L3	L4	Q1	R	R1	S	ØAA	
401 N12A	355	463	1050	651	417	22	23	14	23
451 N12A	355	458	1060	661	412	22	23	14	33
501 N12A	355	463	1120	720	417	22,5	23	14	35
561 N12A	364	532	1180	762	476	27	28	17	40
631 N12A	364	535	1250	832	479	27	28	17	45
711 N12A	542	605	1500*	894*	539	32	33	19	60
801 N12A	582	614	1600	954	548	32	33	19	70
901 N12A	682	650	1800	1038	572	40	39	21	100
1001 N12A	782	710	2100	1238	632	40	39	21	154

\* Para motores de talla 250, esta cota aumenta en 100 mm  
For motor size 250, increase this dimension 100 mm

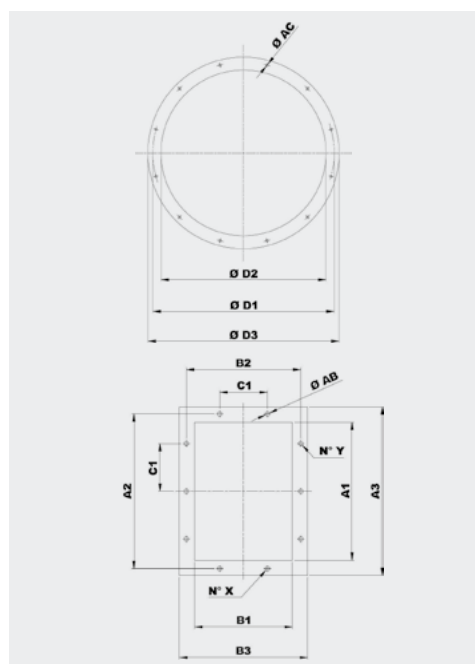

Modelo Model	Brida aspiración Inlet flange					
	Tipo brida Bride type	Ø D1	Ø D2	Ø D3	Ø AC	Agujeros Holes
401	224	265	228	298	8	8
451	250	292	254	324	10	8
501	280	332	285	365	10	8
561	315	366	320	400	10	8
631	355	405	360	440	10	8
711	400	448	405	485	10	12
801	450	497	455	535	10	12
901	500	551	505	585	10	12
1001	560	629	566	666	10	12

Modelo Model	Brida descarga Discharge flange										
	Tipo brida Bride type	A1	B1	A2	B2	A3	B3	C1	Ø AB	N°X	N°Y
401	200x140	205	146	241	182	275	216	112	12	2+2	2+2
451	224x160	229	164	265	200	299	234	112	12	2+2	2+2
501	250x180	256	183	292	219	326	253	112	12	2+2	3+3
561	280x200	288	205	332	249	368	285	125	12	2+2	3+3
631	315x224	322	229	366	273	402	309	125	12	2+2	3+3
711	355x250	361	256	405	300	441	336	125	12	2+2	3+3
801	400x280	404	288	448	332	484	368	125	12	3+3	4+4
901	450x315	453	322	497	366	533	402	125	12	3+3	4+4
1001	500x355	507	361	551	405	587	441	125	12	3+3	4+4

# RODETE ÁLABES CURVADOS HACIA ATRÁS - ACOPLAMIENTO A TRANSMISIÓN BACKWARD CURVED IMPELLER - BELT DRIVE



**DIMENSIONES (mm) (modelos desde 1121 hasta 2001) / DIMENSIONS (mm) (models from 1121 to 2001)**

DESCARGA NO ORIENTABLE  
DISCHARGE NON ADJUSTABLE

**EJECUCIÓN B**  
Con rodete de refrigeración,  
contactar con oficina técnica.

**CONFIGURATION B**  
With cooling impeller,  
contact our technical office.

**ORIENTACIONES / POSITIONS**

	0°	45°	90°	135°	180°	225°	270°	315°
	H1	H2	H3	H4	H5			

Para estas orientaciones, contactar con oficina técnica  
 For these positions, please contact our technical office

Tipo ventilador Fan type	Ventilador Fan											Eje Shaft		Base Base															
	A	B	C	ØD1	E	F	G	H					HT	LT	ØD	L2	L	L1	M	N	O	P2	R	S	T	U	V	Y	ØAA
	H1	H2	H3	H4	H5																								
FI 1121 N1A	1420	840	770	698	626	760	282	850	850	750	1000	1000	1170	1600	80	170	1268	1348	710	404	80	589	600	55	710	35	1194	257	24
FI 1251 N1A	1647	860	866	775	706	946	317	950	950	850	1120	1120	1985	1806	80	170	1400	1480	800	453	80	655	710	45	543	35	1333	272	24
FI 1401 N1A	1732	1060	970	861	790	960	354	1060	950	1250	1250	1250	2220	2020	80	170	1560	1640	935	507	80	725	780	55	652	35	1522	354	24
FI 1601 N1A	1984	1254	1082	958	884	1060	400	1200	1120	1060	1400	1400	2482	2314	90	170	1750	1850	1102	569	100	820	917	65	744	45	1771	405	28
FI 1801 N1A	2098	1406	1217	1067	999	1180	327	1330	1250	1180	1550	1400	2767	2586	100	210	1940	2070	1102	638	120	915	917	65	823	55	1860	439	28
FI 2001 N1A	2175	1558	2955	1200	1112	1320	366	1500	1400	1320	1800	1600	3153	2878	100	210	2150	2270	1102	715	120	1015	917	65	900	55	1937	478	28

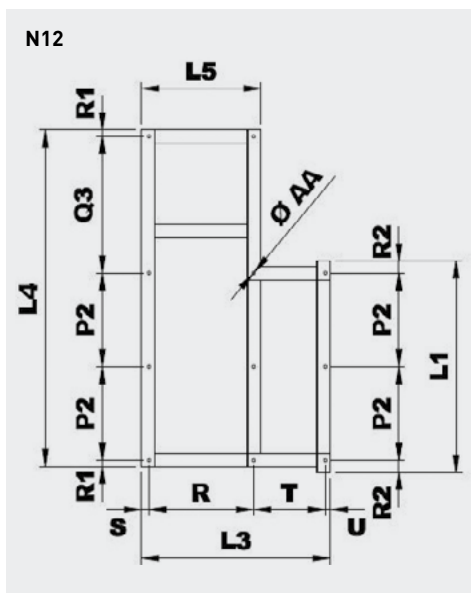

Modelo Model	Bancada ejecución 12 Base frame arrangement 12													Peso Weight (kg)
	P2	L1	L3	L4	L5	Q3	R	R1	R2	S	T	U	ØAA	
1121 N12A	589	1348	1194	2334	710	1066	600	45	85	55	504	35	24	230
1251 N12A	655	1480	1333	2630	800	1230	710	45	85	45	710	35	24	252
1401 N12A	725	1640	1522	2800	890	1240	780	55	95	55	652	35	24	285
1601 N12A	820	1850	1771	2945	1047	1195	917	55	105	65	744	45	28	335
1801 N12A	915	2070	1860	3245	1047	1295	917	60	120	65	823	55	28	385
2001 N12A	1015	2270	1937	3500	1047	1350	917	60	120	65	900	55	28	430

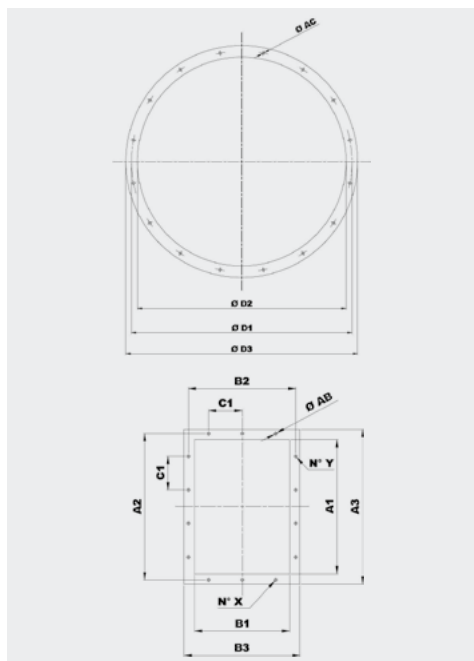

Modelo Model	Brida aspiración Inlet flange					
	Tipo brida Bride type	Ø D1	Ø D2	Ø D3	Ø AC	Agujeros Holes
1121	630	698	636	736	10	12
1251	710	775	716	816	12	16
1401	800	861	806	906	12	16
1601	900	958	906	1006	12	16
1801	1000	1067	1007	1107	12	24
2001	1120	1200	1128	1248	12	24

Modelo Model	Brida descarga Discharge flange										
	Tipo brida Bride type	A1	B1	A2	B2	A3	B3	C1	Ø AB	N°X	N°Y
1121	560x400	569	404	629	464	669	504	160	14	4+4	3+3
1251	630x450	638	453	698	513	738	553	160	14	4+4	3+3
1401	710x500	715	507	775	567	815	607	160	14	5+5	3+3
1601	800x560	801	569	871	639	921	689	200	14	4+4	3+3
1801	900x630	898	638	968	708	1018	758	200	14	4+4	5+5
2001	1000x710	1007	715	1077	785	1127	835	200	14	4+4	5+5

AMORTIGUADORES / SILENT BLOCKS

Amortiguadores recomendados / Suggested silent blocks		
Ventilador / Fan	Ejecución 9 / Arrangement 9	Ejecución 12 / Arrangement 12
401	4 x AM 30 - 30 x 30	4 x AM 40 - 40 x 30
451	4 x AM 30 - 30 x 30	4 x AM 40 - 40 x 30
501/2	4 x AM 40 - 40 x 30	4 x AM 50 - 50 x 40
561/2	4 x AM 50 - 50 x 40	4 x AM 50 - 50 x 40
631/2	4 x AM 75 - 75 x 50	4 x AM 75 - 75 x 50
711/2	4 x AM 75 - 75 x 50	4 x AM 75 - 75 x 50
801/2	4 x AM 75 - 75 x 50	4 x AZ 39 - 140 x 39
901/2	4 x AZ 39 - 140 x 39	4 x AZ 39 - 140 x 39
1001/2	4 x AZ 39 - 140 x 39	6 x AZ 39 - 140 x 39
1121/2	6 x AZ 39 - 140 x 39	6 x AZ 51 - 132 x 51
1251	6 x AZ 63 - 150 x 63	6 x AZ 51 - 132 x 51
1401	-	6 x AZ 51 - 132 x 51
1601	-	6 x AZ 63 - 150 x 63
1801	-	6 x AZ 63 - 150 x 63
2001	-	6 x AZ 63 - 150 x 63

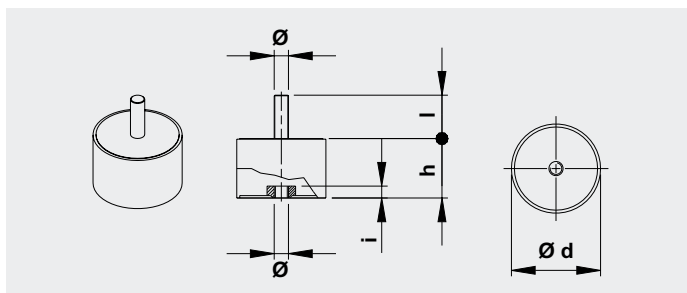

Tipo Type	Carga para 4 soportes Load for 4 supports (kg)	d	h	Ø	l	Peso Weight (kg)
AM30	81÷140	30	30	M8	20	0,05
AM40	141÷224	40	30	M8	23	0,10
AM50	225÷315	50	40	M10	28	0,20
AM75	316÷630	75	50	M12	37	0,50

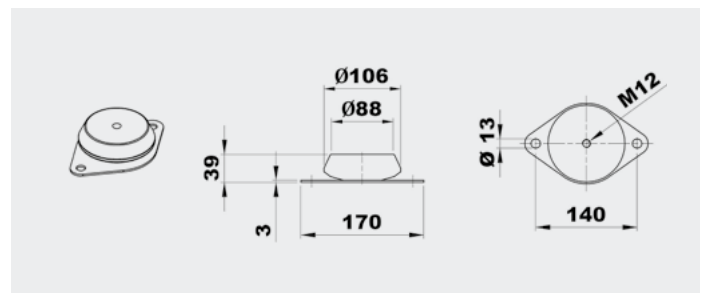

Tipo Type	Carga para 4 soportes Load for 4 supports (kg)	Peso Weight (kg)
AZ 39	631÷1250	0,7

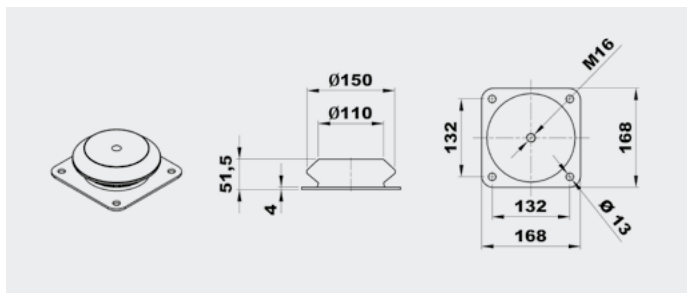

Tipo Type	Carga para 4 soportes Load for 4 supports (kg)	Peso Weight (kg)
AZ 51	1251÷2500	1,8

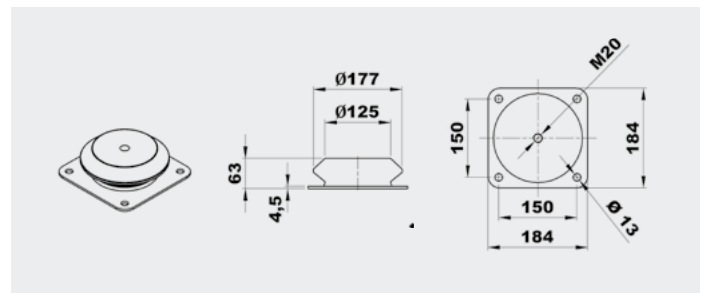

Tipo Type	Carga para 4 soportes Load for 4 supports (kg)	Peso Weight (kg)
AZ 63	2501÷5000	2,5